

THIS INFORMATION IS CONFIDENTIAL AND IS DISCLOSED TO YOU ON CONDITION THAT NO FURTHER DISCLOSURE IS MADE BY YOU TO OTHER THAN AMP PERSONNEL WITHOUT WRITTEN AUTHORIZATION FROM AMP (TAIWAN) LTD. DIMENSIONS IN MILLIMETERS. DO NOT SCALE PRINT.

NUMBER  
C-1734493

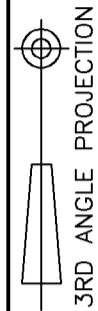

METRIC

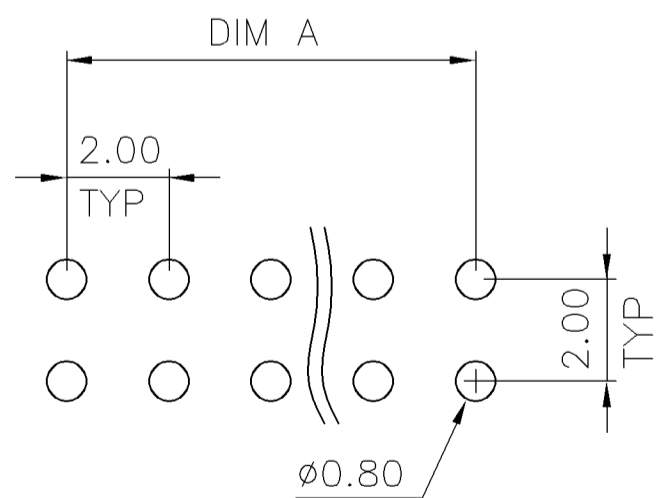
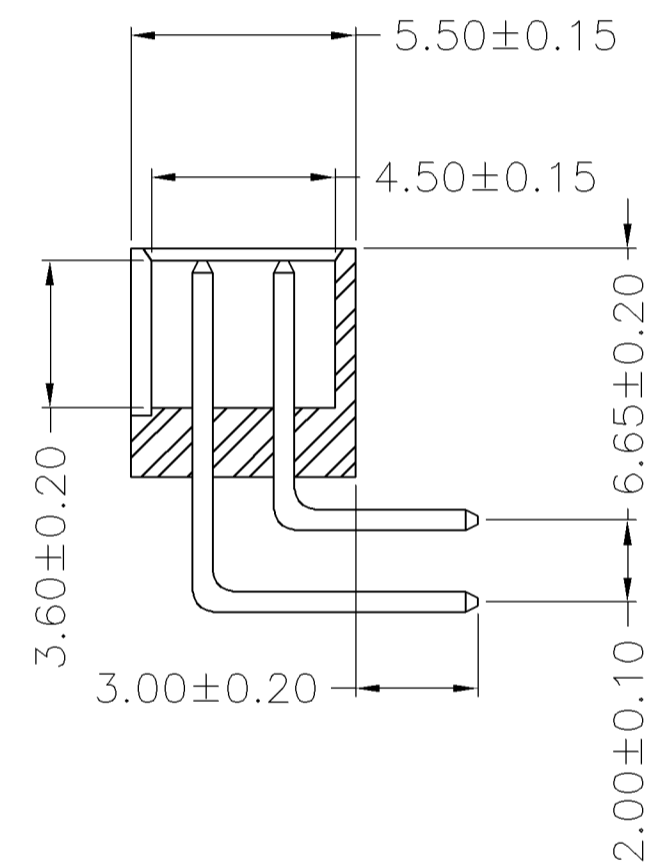
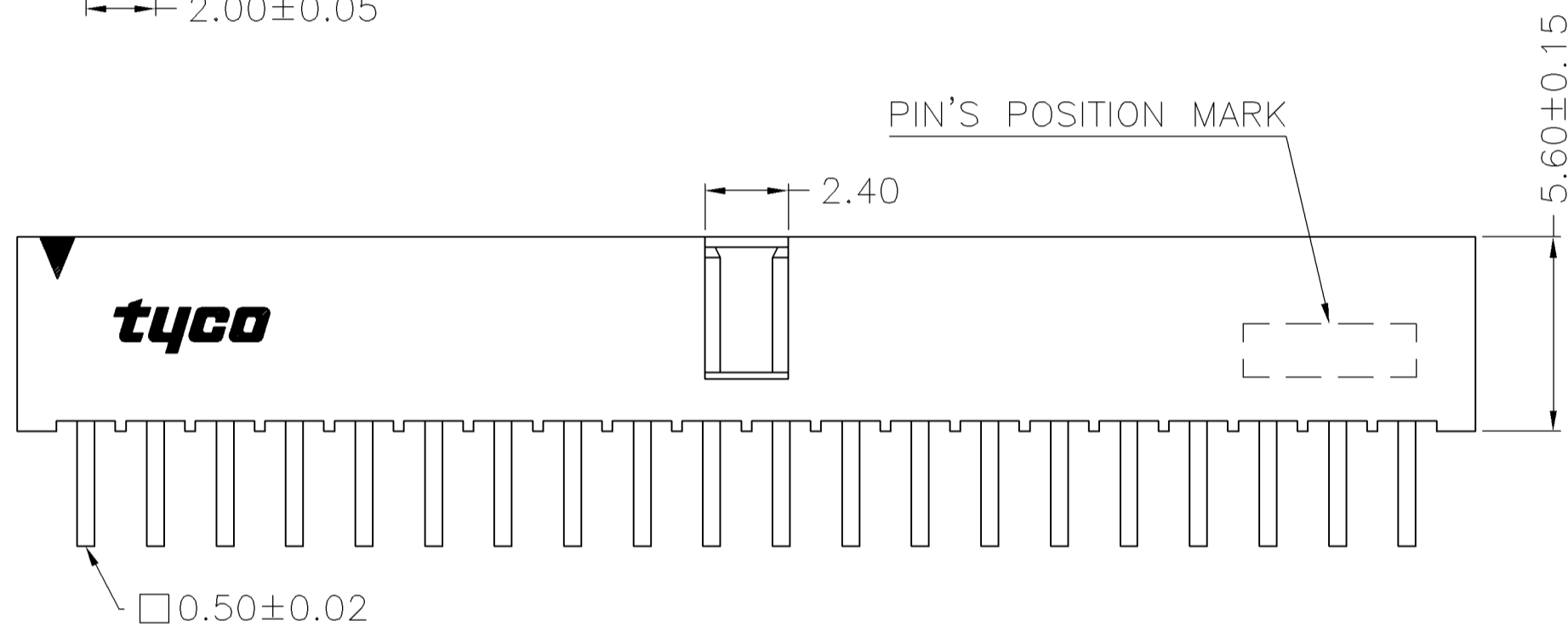
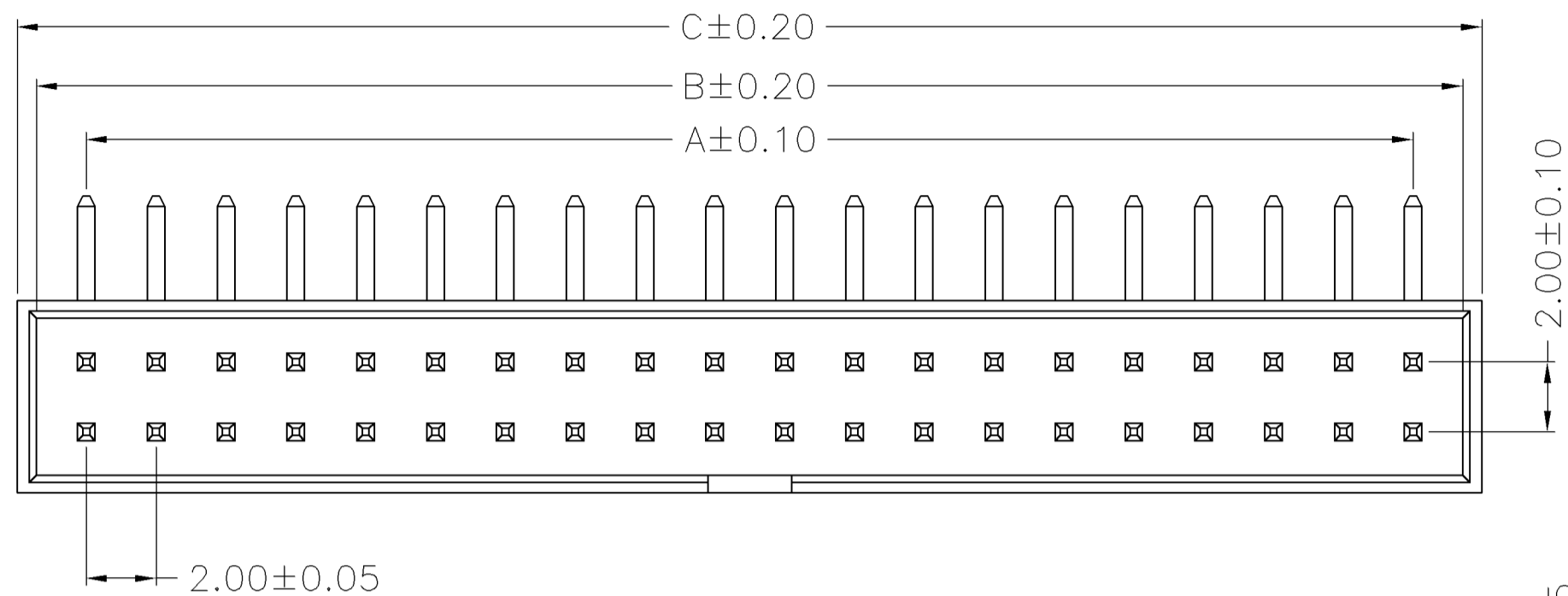

RECOMMENDED PCB LAYOUT (THICKNESS: 1.6mm)  
(TOP VIEW) (TOLERANCE: ±0.05)

NOTE:

- MATERIAL:  
HOUSING: NYLON 6T, UL 94V-0, COLOR: BLACK.  
CONTACT: BRASS, THICKNESS=0.50mm.
- FINISH:  
CONTACT: 8 u" MIN. GOLD PLATED ON CONTACT AREA,  
100 u" MIN. MATTE TIN PLATED ON SOLDERTAILS,  
50 u" MIN. NICKEL UNDERPLATED OVERALL.
- WAVE SOLDER CAPABLE TO 265°C PER TYCO SPEC 109-202, CONDITION B.

POS.	A	B	C	PART NUMBER
64	62.00	64.85	65.95	6-1734493-4
62	60.00	62.85	63.95	6-1734493-2
60	58.00	60.85	61.95	6-1734493-0
58	56.00	58.85	59.95	5-1734493-8
56	54.00	56.85	57.95	5-1734493-6
54	52.00	54.85	55.95	5-1734493-4
52	50.00	52.85	53.95	5-1734493-2
50	48.00	50.85	51.95	5-1734493-0
48	46.00	48.85	49.95	4-1734493-8
46	44.00	46.85	47.95	4-1734493-6
44	42.00	44.85	45.95	4-1734493-4
42	40.00	42.85	43.95	4-1734493-2
40	38.00	40.85	41.95	4-1734493-0
38	36.00	38.85	39.95	3-1734493-8
36	34.00	36.85	37.95	3-1734493-6
34	32.00	34.85	35.95	3-1734493-4
32	30.00	32.85	33.95	3-1734493-2
30	28.00	30.85	31.95	3-1734493-0
28	26.00	28.85	29.95	2-1734493-8
26	24.00	26.85	27.95	2-1734493-6
24	22.00	24.85	25.95	2-1734493-4
22	20.00	22.85	23.95	2-1734493-2
20	18.00	20.85	21.95	2-1734493-0
18	16.00	18.85	19.95	1-1734493-8
16	14.00	16.85	17.95	1-1734493-6
14	12.00	14.85	15.95	1-1734493-4
12	10.00	12.85	13.95	1-1734493-2
10	8.00	10.85	11.95	1-1734493-0
8	6.00	8.85	9.95	0-1734493-8

TOLERANCES UNLESS OTHERWISE SPECIFIED: DWN		O. HU	
0 PLC ±	26-JUN-2007	Tyco Electronics Corporation Tyco Electronics Corporation Taipei, Taiwan	
1 PLC ±0.20	CHK	NAME	
2 PLC ±0.15	26-JUN-2007	AMPMODU 2.0MM PITCH, RIGHT ANGLE, DUAL ROW, THRU-HOLE.	
3 PLC ±0.10	APVD	LOC	
ANGLES ±	W.J. KE	SIZE	DRAWING NO
	26-JUN-2007	A <sub>3</sub>	C-1734493
MATERIAL	PRODUCT SPEC	SCALE	REV
SEE NOTE	108-57197	--	A1
FINISH	QUALIFICATION TEST REPORT	SHEET	
SEE NOTE	501-57197	1 OF 2	
	WEIGHT		

A1	ADD PIN'S POSITION	ECR-07-014928	OH	29JUN 2007
A	FIRST RELEASED		OH	30MAR 2006
LTR	REVISION RECORD	ECN	DWN	DATE

THIS INFORMATION IS CONFIDENTIAL AND IS DISCLOSED TO YOU ON CONDITION THAT NO FURTHER DISCLOSURE IS MADE BY YOU TO OTHER THAN AMP PERSONNEL WITHOUT WRITTEN AUTHORIZATION FROM AMP (TAIWAN) LTD. DIMENSIONS IN MILLIMETERS. DO NOT SCALE PRINT.

PRINT DIST  
DW

METRIC

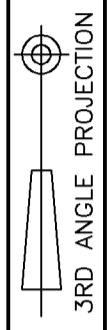

NUMBER  
C-1734493

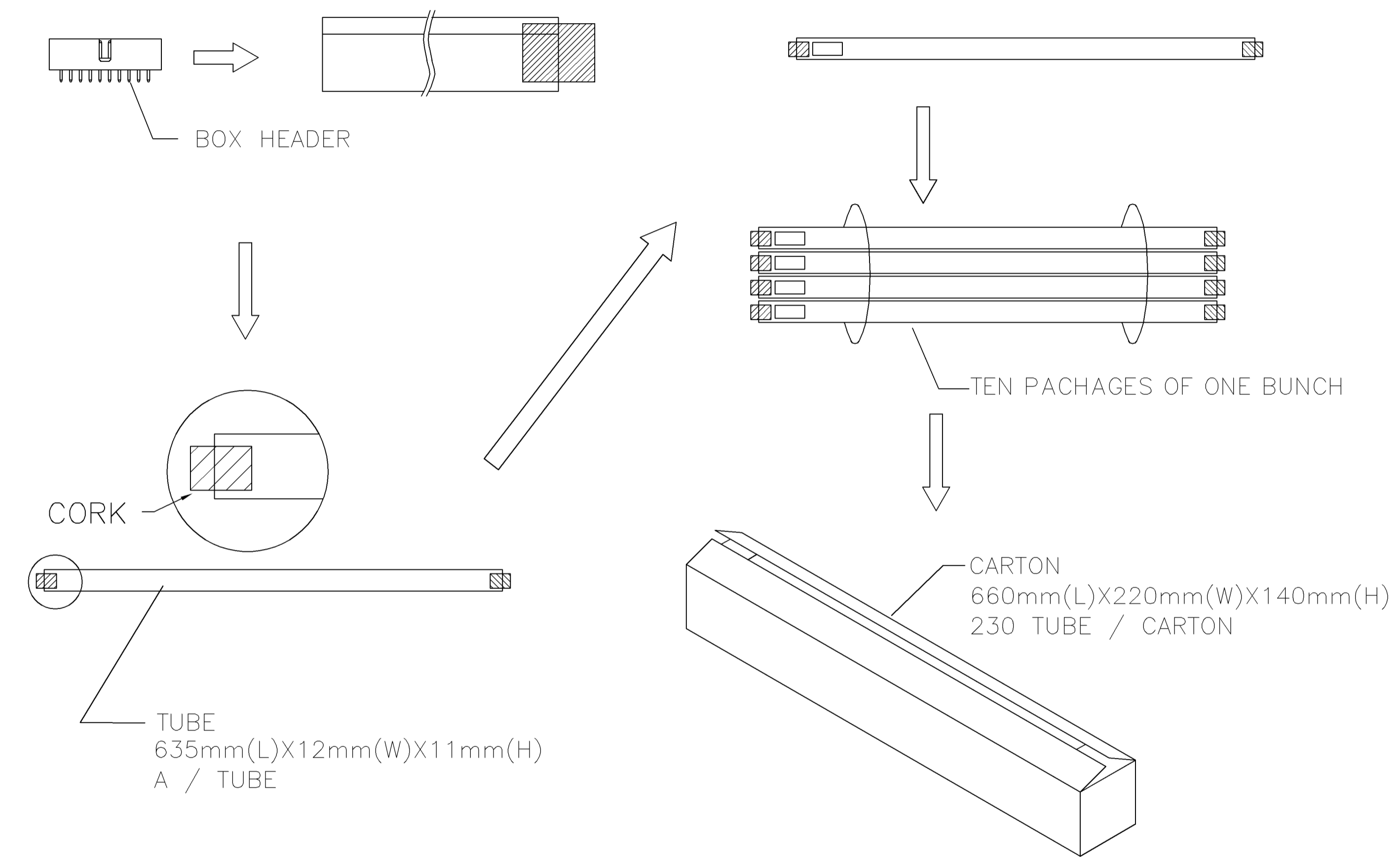

2,070	9	64	6-1734493-4
2,070	9	62	6-1734493-2
2,070	9	60	6-1734493-0
2,300	10	58	5-1734493-8
2,300	10	56	5-1734493-6
2,300	10	54	5-1734493-4
2,530	11	52	5-1734493-2
2,530	11	50	5-1734493-0
2,760	12	48	4-1734493-8
2,760	12	46	4-1734493-6
2,990	13	44	4-1734493-4
2,990	13	42	4-1734493-2
3,220	14	40	4-1734493-0
3,450	15	38	3-1734493-8
3,450	15	36	3-1734493-6
3,680	16	34	3-1734493-4
3,910	17	32	3-1734493-2
4,140	18	30	3-1734493-0
4,600	20	28	2-1734493-8
4,830	21	26	2-1734493-6
5,290	23	24	2-1734493-4
5,750	25	22	2-1734493-2
6,210	27	20	2-1734493-0
6,900	30	18	1-1734493-8
7,590	33	16	1-1734493-6
8,510	37	14	1-1734493-4
9,660	42	12	1-1734493-2
11,500	50	10	1-1734493-0
13,800	60	8	0-1734493-8
PCS/ CARCON	PCS/ TUBE	POS.	PART NUMBER

TOLERANCES UNLESS OTHERWISE SPECIFIED: 0 PLC ± 1 PLC ± 2 PLC ± 3 PLC ± ANGLES ±°	DWN	O. HU	Tyco Electronics Corporation Tyco Electronics Taipei, Taiwan		
		26-JUN-2007	NAME	AMPMODU 2.0MM PITCH, RIGHT ANGLE, DUAL ROW, THRU-HOLE.	
MATERIAL  SEE NOTE	CHK	S. HOU	LOC		SIZE
		26-JUN-2007	APVD	W.J. KE	DRAWING NO
FINISH  SEE NOTE	PRODUCT SPEC	26-JUN-2007	QUALIFICATION TEST REPORT	DW	A <sub>3</sub>
	WEIGHT			SCALE	--
				DRAWING NO	C-1734493
				REV	A1
				SHEET	2 OF 2

LTR	SEE SHEET 1.	ECN	DWN	CHK	DATE
	REVISION RECORD				